

Standard executions		
Version	Symbol	Type
Double acting, not magnetic		DU
Double acting, magnetic		DUM
Double acting, not magnetic, anti-rotating		DUN
Double acting, magnetic, anti-rotating		DUNM



Series of compact cylinders double acting.

The barrel with grooves allow the mounting of the magnetic reed switches directly in the tube without brackets; the magnetic reed switches will not protrude out the barrel profile. One or more magnetic reed switches can be mounted on the cylinder.

Six sides of this cylinder can be attached unto objects for space-saving purpose.

For the magnetic reed switches type ASC see from page 1.110.2.
For rod mountings see from page 1.85.1.

Options	Suffix
Special on request	/ S

How to order: 20/30 DUM

20	/	30	DUM	
Bore	/	Stroke	Type	Option

Technical data						
Fluid	Compressed filtered air with or without lubrication. Lubrication, if started, must be continued.					
Bore	Ø 6	Ø 10	Ø 16	Ø 20	Ø 20	Ø 32
Pressure range	3 ÷ 7 bar	1,5 ÷ 7 bar		1 ÷ 7 bar		
Temperature range	-10 °C ÷ + 60°C					

Bore (mm)	Standard stroke DU	Standard stroke DUM	Standard stroke DUN	Standard stroke DUNM
6	-	5, 10, 15, 20, 25, 30	-	-
10	-	5, 10, 15, 20, 25, 30	-	-
16	5, 10, 15, 20, 25, 30	5, 10, 15, 20, 25, 30	5, 10, 15, 20, 25, 30	5, 10, 15, 20, 25, 30
20	5, 10, 15, 20, 25, 30, 40, 50	5, 10, 15, 20, 25, 30, 40, 50	5, 10, 15, 20, 25, 30, 40, 50	5, 10, 15, 20, 25, 30, 40, 50
25	5, 10, 15, 20, 25, 30, 40, 50	5, 10, 15, 20, 25, 30, 40, 50	5, 10, 15, 20, 25, 30, 40, 50	5, 10, 15, 20, 25, 30, 40, 50
32	5, 10, 15, 20, 25, 30, 40, 50	5, 10, 15, 20, 25, 30, 40, 50	5, 10, 15, 20, 25, 30, 40, 50	5, 10, 15, 20, 25, 30, 40, 50

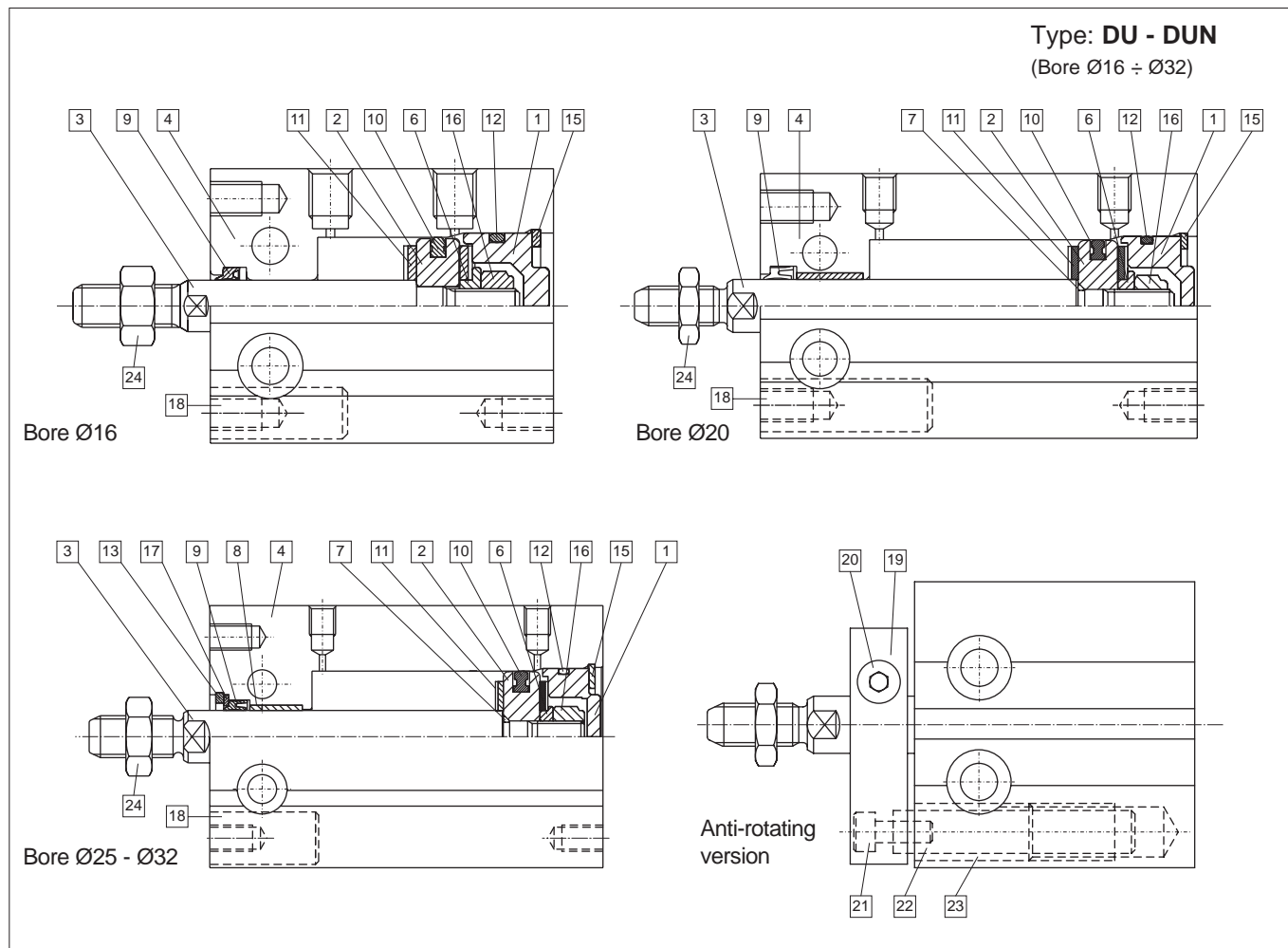

Materials			
1	End cover	Hard anodised aluminium alloy	
2	Piston	Brass ($\varnothing 6 \div \varnothing 10$) Hard anodised aluminium ($\varnothing 16 \div \varnothing 32$)	
3	Piston rod	Stainless steel ($\varnothing 6 \div \varnothing 16$) - Carbon steel ($\varnothing 20 \div \varnothing 32$)	
4	Cylinder tube	Hard anodised aluminium alloy	
5	Magnet holder	Hard anodised aluminium alloy	
6	T-washer	Carbon steel nickel plating	
7	O-ring	Nitrile rubber NBR	
8	Oilless bearing	Oil-impregnated sintered alloy	
9	Rod packing	PU ($\varnothing 6 \div \varnothing 16$) - Nitrile rubber NBR ($\varnothing 20 \div \varnothing 32$)	
10	Piston packing	Nitrile rubber NBR	
11	Rubber lining	Nitrile rubber NBR	
12	Cylinder gasket	Nitrile rubber NBR	
13	Retaining ring	Carbon steel nickel plating	
14	Magnet	Magnetic material	
15	Retaining ring	Carbon steel nickel plating	
16	Piston nut	Carbon steel galvanized	
17	Rod washer	Stainless steel	
18	Screw plug	Hard anodised aluminium alloy	
19	Guide plate	Hard anodised aluminium alloy	
20	Screw	Carbon steel nickel plating	
21	Screw	Carbon steel nickel plating	
22	Guide stem	Carbon steel	
23	Oilless bearing	Oil-impregnated sintered alloy	
24	Rod end nut	Stainless steel ($\varnothing 6 \div \varnothing 10$) Carbon steel nickel plating ($\varnothing 16 \div \varnothing 32$)	

Type: **DUM - DUNM**
(Bore $\varnothing 6 \div \varnothing 32$)

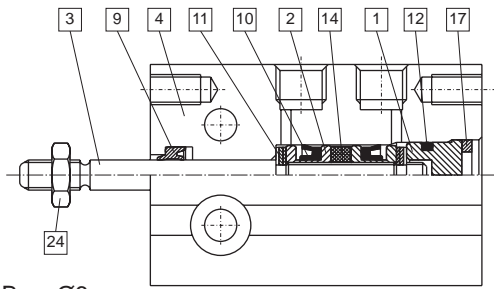

Bore $\varnothing 6$

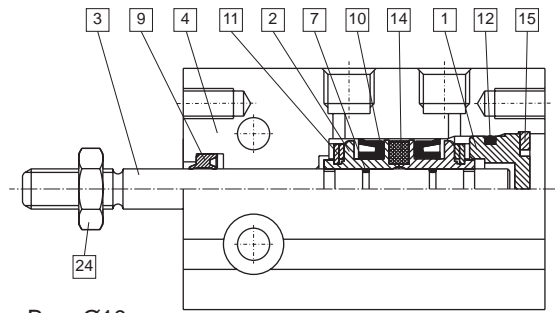

Bore $\varnothing 10$

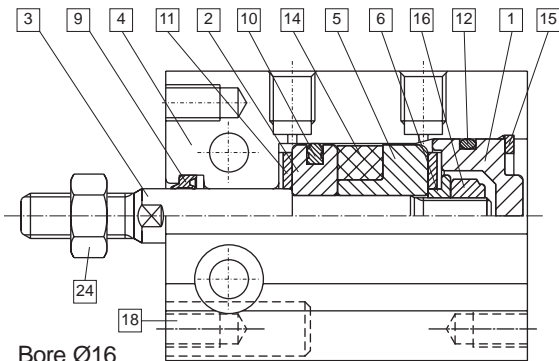

Bore $\varnothing 16$

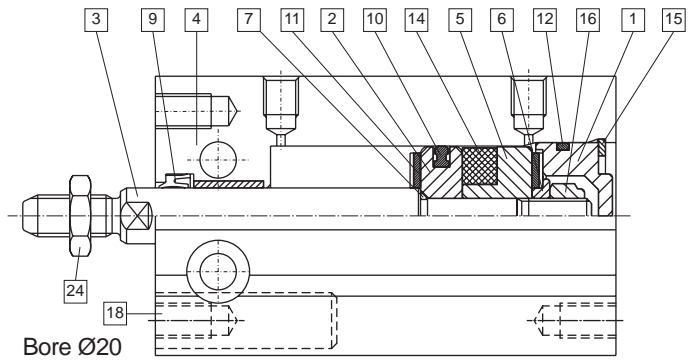

Bore $\varnothing 20$

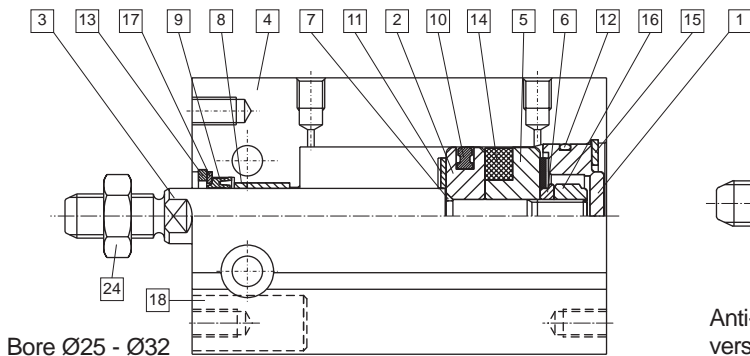

Bore $\varnothing 25 - \varnothing 32$

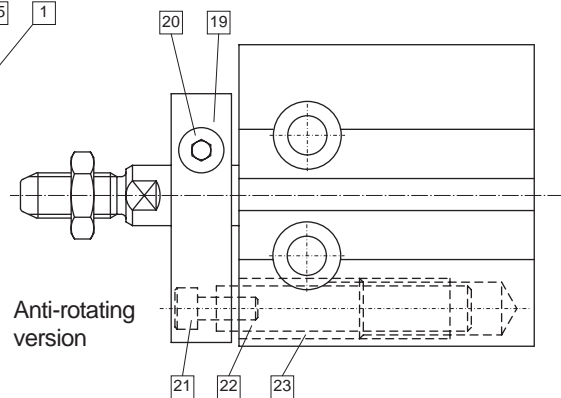

Anti-rotating version

Materials

1 End cover	Hard anodised aluminium alloy	13 Retaining ring	Carbon steel nickel plating
2 Piston	Brass ($\varnothing 6 \div \varnothing 10$) Hard anodised aluminium ($\varnothing 16 \div \varnothing 32$)	14 Magnet	Magnetic material
3 Piston rod	Stainless steel ($\varnothing 6 \div \varnothing 16$) - Carbon steel ($\varnothing 20 \div \varnothing 32$)	15 Retaining ring	Carbon steel nickel plating
4 Cylinder tube	Hard anodised aluminium alloy	16 Piston nut	Carbon steel galvanized
5 Magnet holder	Hard anodised aluminium alloy	17 Rod washer	Stainless steel
6 T-washer	Carbon steel nickel plating	18 Screw plug	Hard anodised aluminium alloy
7 O-ring	Nitrile rubber NBR	19 Guide plate	Hard anodised aluminium alloy
8 Oilless bearing	Oil-impregnated sintered alloy	20 Screw	Carbon steel nickel plating
9 Rod packing	PU ($\varnothing 6 \div \varnothing 16$) - Nitrile rubber NBR ($\varnothing 20 \div \varnothing 32$)	21 Screw	Carbon steel nickel plating
10 Piston packing	Nitrile rubber NBR	22 Guide stem	Carbon steel
11 Rubber lining	Nitrile rubber NBR	23 Oilless bearing	Oil-impregnated sintered alloy
12 Cylinder gasket	Nitrile rubber NBR	24 Rod end nut	Stainless steel ($\varnothing 6 \div \varnothing 10$) Carbon steel nickel plating ($\varnothing 16 \div \varnothing 32$)

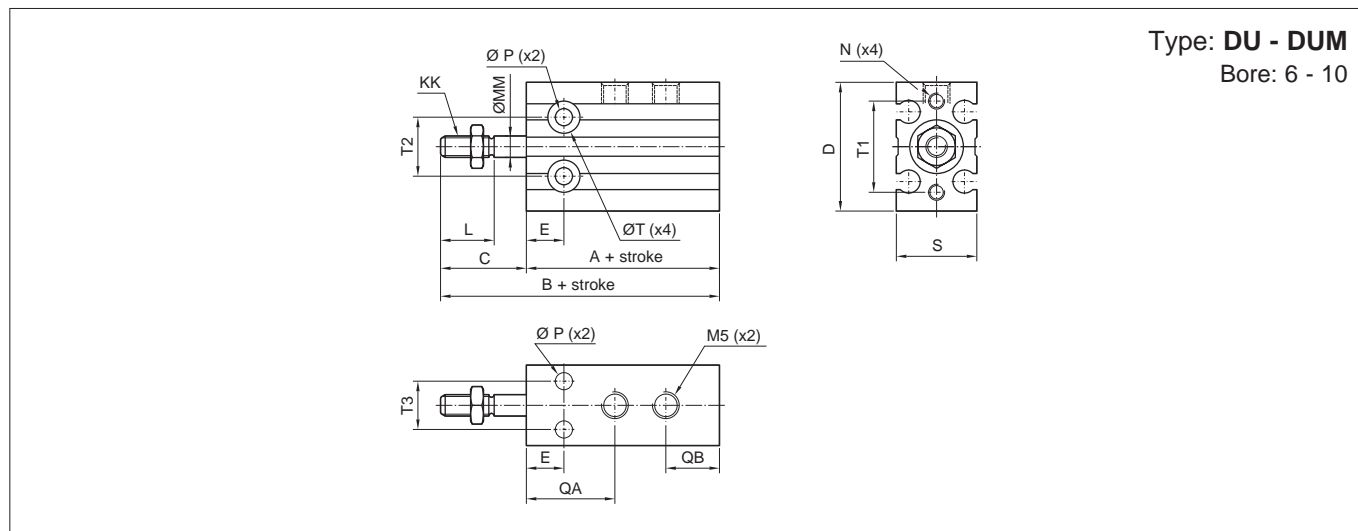

Type: **DU - DUM**
Bore: 6 - 10

Ø (mm)	DU		DUM		C	D	E	F	FB	L	KK	MM	N	P	QA	QB	S
	A	B	A	B													
6	-	-	33	46	13	22	7	-	-	7	M3	3	M3	3,2	15	10	13
10	-	-	36	52	16	24	7	-	-	10	M4	4	M3	3,2	15	11	18

Ø (mm)	T	T1	T2	T3													
6	Ø 6 depth 4.8	17	10	7													
10	Ø 6 depth 5	17	10	7													

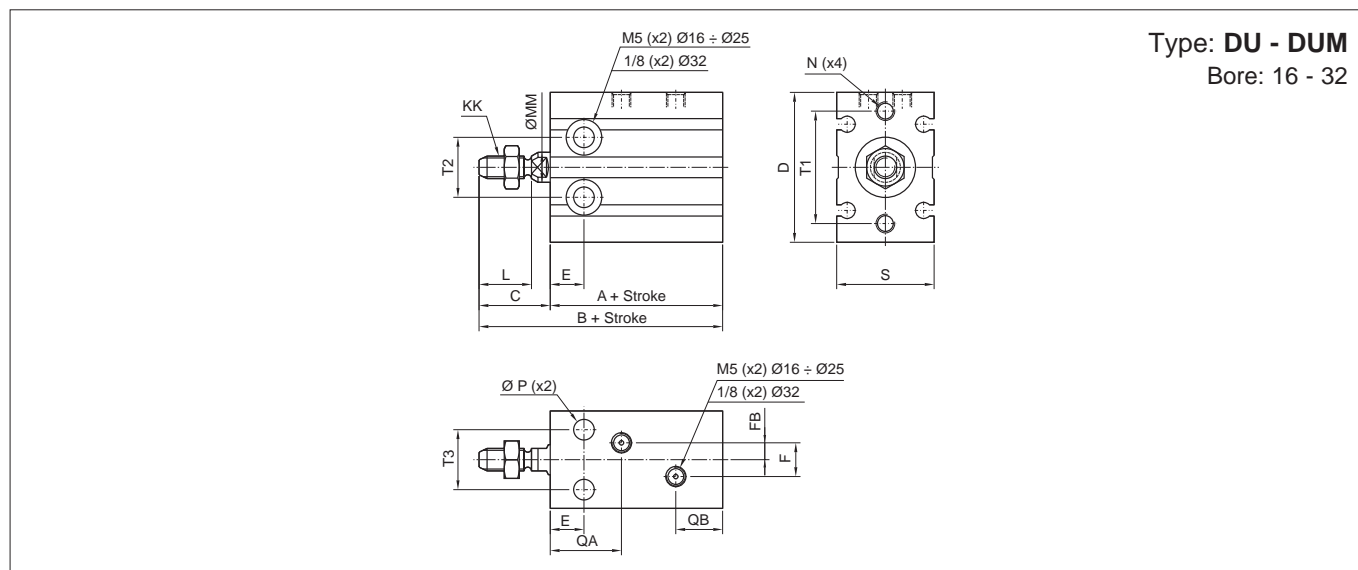

Type: **DU - DUM**
Bore: 16 - 32

Ø (mm)	DU		DUM		C	D	E	F	FB	L	KK	MM	N	P	QA	QB	S
	A	B	A	B													
16	30	46	40	56	16	32	7	4	2	12,5	M5	6	M4	4,3	14	11,5	20
20	36	55	46	65	19	40	9	9	4,5	14	M6	8	M5	5,2	18	12,5	26
25	40	63	50	73	23	50	10	9	4,5	18	M8	10	M5	5,5	21,5	12,5	32
32	42	69	52	79	27	62	11	13,5	4,5	22	M10	12	M6	6,6	23	13	40

Ø (mm)	T	T1	T2	T3													
16	Ø 7,6 depth 6,5	25	14	12													
20	Ø 9 depth 7,6	30	16	16													
25	Ø 9,5 depth 9	38	20	20													
32	Ø 11 depth 11	48	24	24													

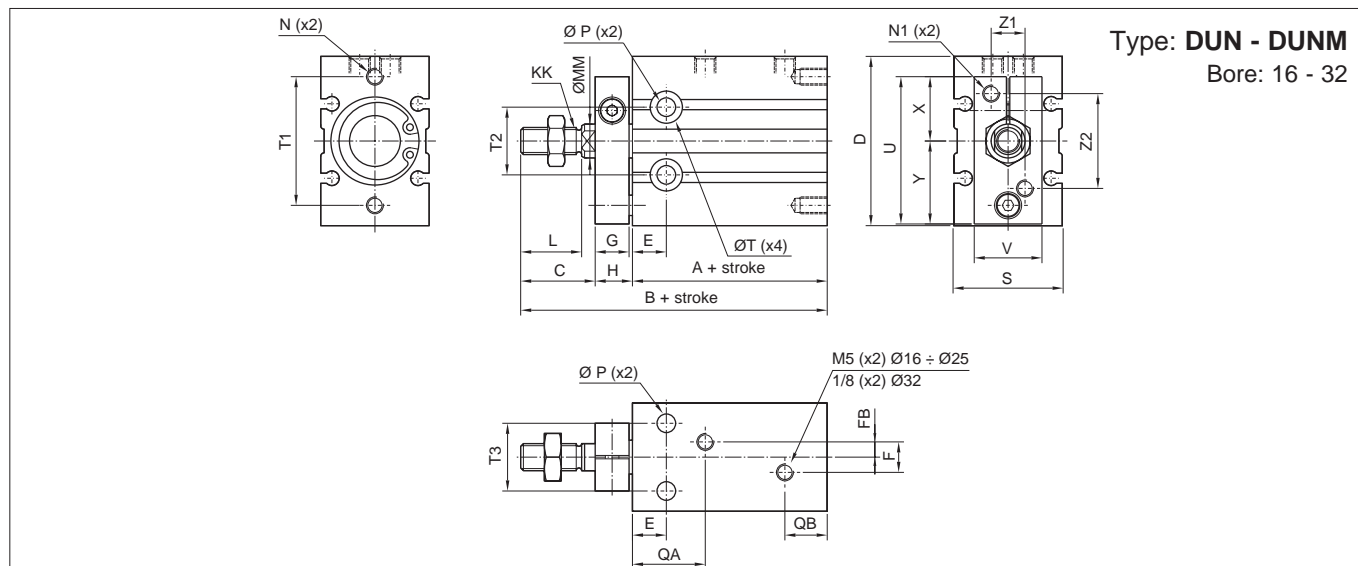

Ø (mm)	A	B	A	B	C	D	E	F	FB	G	H	L	KK	MM	N	N1	P
	DU		DUM														
16	30	56	40	66	17	32	7	4	2	8	9	12,5	M5	6	M4	M4	4,3
20	36	65	46	75	20	40	9	9	4,5	8	9	14	M6	8	M5	M4	5,2
25	40	73	50	83	22	50	10	9	4,5	10	11	18	M8	10	M5	M5	5,5
32	42	84	52	94	29	62	11	13,5	4,5	12	13	22	M10	12	M6	M5	6,5

Ø (mm)	T	T1	T2	T3	QA	QB	S	U	V	X	Y	Z1	Z2			
16	Ø 7,6 depth 6,5	25	14	12	14	11,5	20	28	13	12,5	15,5	6	18			
20	Ø 9 depth 7,6	30	16	16	18	12,5	26	33	16	13,5	19,5	8	20			
25	Ø 9,5 depth 9	38	20	20	21,5	12,5	32	43,5	20	19	24,5	10	28			
32	Ø 11 depth 11	48	24	24	23	13	40	51,5	24	21	30,5	12	32			

