

Stainless Steel Round Cylinders

Bores from 32 to 63 mm

Double acting



New

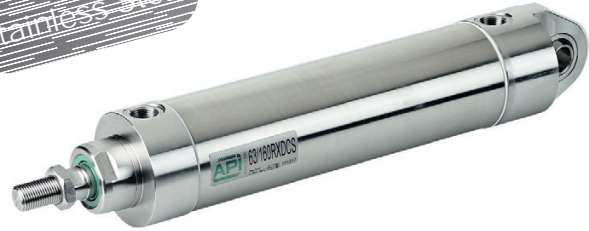

Standard executions		
Version	Symbol	Type
Front threaded end cap mounting. Magnetic, adjustable cushioning		RXDVA
Front and rear threaded end caps mounting. Magnetic, adjustable cushioning		RXDVD
Four threaded holes on rear cap. Magnetic, adjustable cushioning		RXDFP
Male hinge fixing (ISO MP4) Magnetic, adjustable cushioning		RXD CM
Male hinge with articulated head (ISO MP6) Magnetic, adjustable cushioning		RXD CS
Narrow female hinge (ISO AB6) Magnetic, adjustable cushioning		RXD CF
Hinge on front end cap. Magnetic, adjustable cushioning		RXD BA
Hinge on rear end cap. Magnetic, adjustable cushioning		RXD BP

New series of stainless steel round cylinder with bores from 32 to 63mm., characterized by an essential design specifically developed to prevent the settling of impurities.

Cylinder body is smooth surface free of chamfers or cavities where dirt can settle.
This series is fully in Stainless Steel AISI 316L.

These features make RXD cylinders specifically suitable for Food&Beverage, Chemical, Pharmaceutical and Medical industries and for all those applications where maximum hygiene and cleaning are required, even in corrosive environments.

RXD Series are available in several configurations bespoke solutions are also possible.

For the magnetic reed switches type ASV see from page 1.110.1
For mounting accessories see from page 5.40.1
For rod accessories see from page 5.20.1

CE II 2Gc IIC T5
II 2Dc T100°C

On request, they can be supplied according to 2014/34/EU - ATEX

NSF Lubrication with synthetic grease long lasting for applications with low start up, granting low friction and a permanent lubrication film.
Fully composed by non-toxic elements conforming to directive FDA section 21 CFR 178 about accidental contact with food (registered NSF H1).

Options	Suffix
Through rod	P
High temperature seals FKM (-20°C ÷ +150°C)	V
Scrape ring only in FKM (-20°C ÷ +80°C)	V1
Low temperature seals EPDM (-40°C ÷ +80°C)	BT
Extended rod (indicate the requested WH dimension in mm. E.g.: WH-100)	WH-
Without adjustable cushionings	D
Adjustable rear cushioning only	D1
Adjustable front cushioning only	D2
Special male thread (indicate the requested thread. E.g. : R-M 10x1,5). The dimension AM of the special thread will be the same as the standard. The cylinder will be supplied without rod nut.	R-M
With bellows for protection of the rod (in this case the dimension WH will be extended according the stroke of the cylinder)	Z
Piston rod scraping ring in nitrile rubber NBR	H
Special on request	/S

The options can be combined (when this is possible).
The suffix of the options are to be added to the model number of the standard product, as shown in the following table.
How to order: 63 / 100 RXDVAP

63	/	100	RXDVA	P
Bore	/	Stroke	Type	Option

Type: **RXDVA**

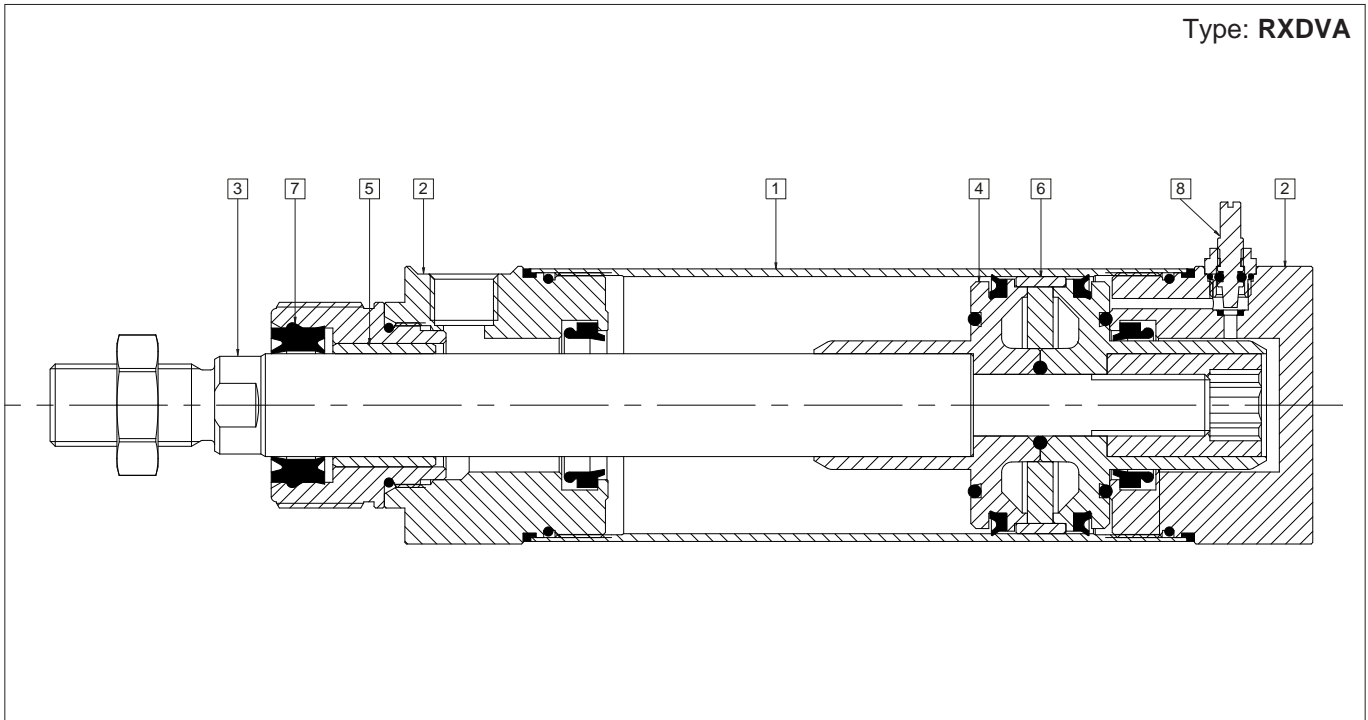

Materials (standard types)

1	Tube and tie-rods	Stainless steel AISI 316L
2	Heads	Stainless steel AISI 316L
3	Rod	Stainless steel AISI 316L, lapped
4	Piston	Die-cast aluminium
5	Bushing	Self-lubricating sintered bronze
6	Guide ring	Natural Delrin
7	Rod seals	Special polyurethane
8	Group cushioning screw	Stainless steel AISI 316L
	Other seals	Nitrile rubber NBR/polyurethane

Technical data

Bore (mm)	32	40	50	63
Fluid	Compressed filtered air with or without lubrication. Lubrication, if started, must be continued.			
Pressure	0,5 ÷ 10 bar			
Temperature range	Standard: -20 °C ÷ +80 °C High temperature (V): -20°C ÷ +150°C Scrape ring only in FKM (-20°C ÷ +80°C) Low temperature (BT): -40°C ÷ +80°C			
Stroke	from 10 mm to 1000 mm			
Cushion length	20	22	25	25
Ports	1/8"	1/4"		3/8"
Rod thread	M10 x 1,25	M12 x 1,25	M16 x 1,5	

Stainless Steel Round Cylinders

Bores from 32 to 63 mm *Standard dimensions*



Type: **RXDVA**

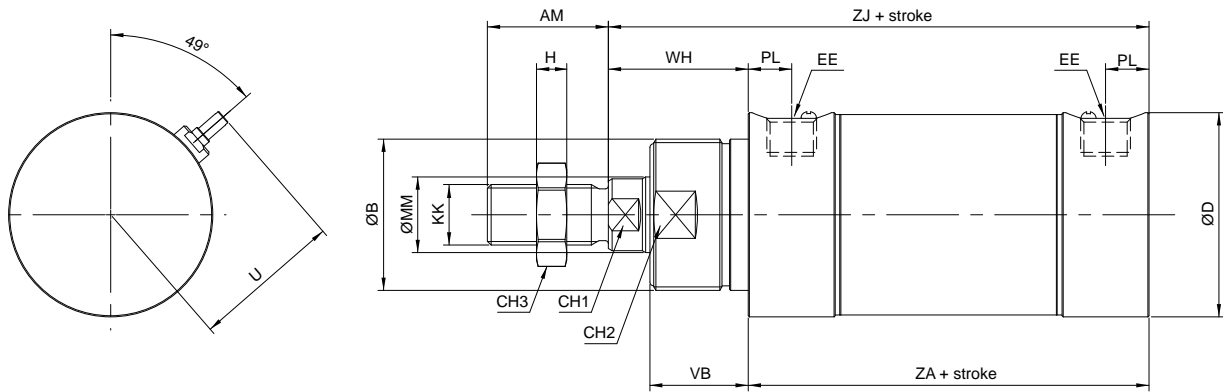

Ø (mm)	AM	ØB	ØD	EE	KK	ØMM f7	PL	VB	U	WH	ZA +1 0	ZJ +1 0	CH1	CH2	CH3	H
32	22	M30x1,5	36	G1/8	M10x1,25	12	10,5	20	26,5	26	94	120	10	29	17	5
40	24	M38x1,5	45	G1/4	M12x1,25	16	12	22	31	30	105	135	13	36	19	6
50	32	M45x1,5	54	G1/4	M16x1,5	20	11,5	26	39,5	37	106	143	17	42	24	8
63	32	M45x1,5	68	G3/8	M16x1,5	20	14,5	25	38,5	37	121	158	17	42	24	8

Type: **RXDVD**

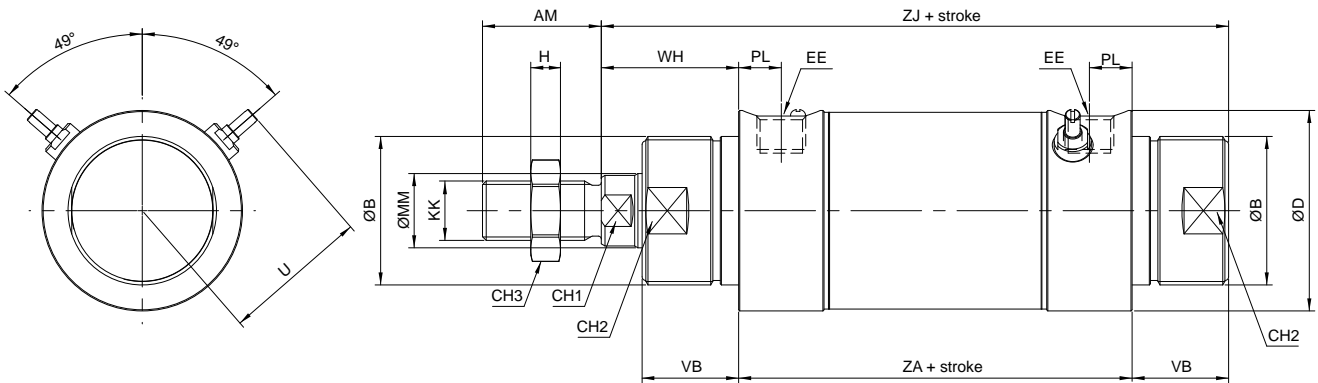

Ø (mm)	AM	ØB	ØD	EE	KK	ØMM f7	PL	VB	U	WH	ZA +1 0	ZJ +1 0	CH1	CH2	CH3	H
32	22	M30x1,5	36	G1/8	M10x1,25	12	10,5	20	26,5	26	94	140	10	29	17	5
40	24	M38x1,5	45	G1/4	M12x1,25	16	12	22	31	30	105	157	13	36	19	6
50	32	M45x1,5	54	G1/4	M16x1,5	20	11,5	26	39,5	37	106	169	17	42	24	8
63	32	M45x1,5	68	G3/8	M16x1,5	20	14,5	25	38,5	37	121	183	17	42	24	8

Stainless Steel Round Cylinders

Bores from 32 to 63 mm *Standard dimensions*



Type: **RXDFP**

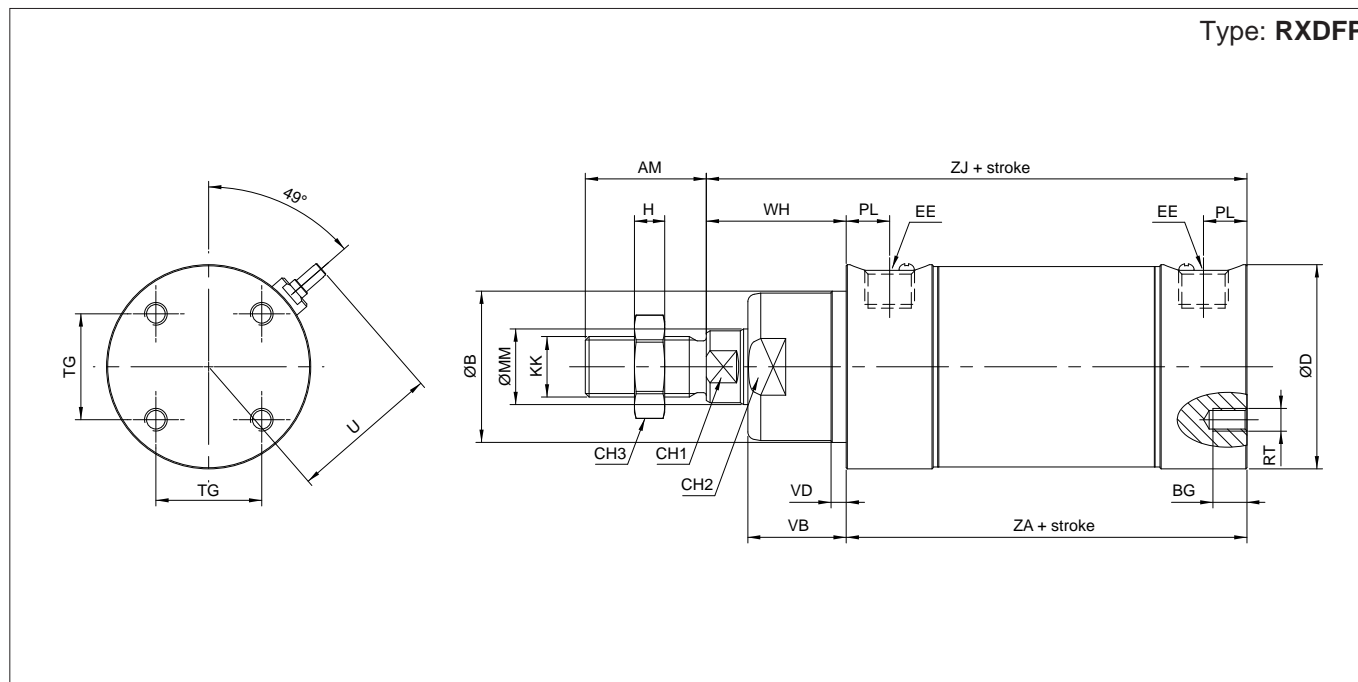

Ø (mm)	AM	ØB d11	BG	ØD	EE	KK	ØMM f7	PL	RT	TG	VB	VD	U	WH	ZA +1 0 stroke	ZJ +1 0 stroke	CH1	CH2	CH3	H
32	22	30	6	36	G1/8	M10x1,25	12	10,5	M4	19	20	4	26,5	26	94	120	10	29	17	5
40	24	35	8	45	G1/4	M12x1,25	16	12	M5	24	22	4	31	30	105	135	13	33	19	6
50	32	40	9	54	G1/4	M16x1,5	20	11,5	M6	28	26	4	39,5	37	106	143	17	38	24	8
63	32	45	12	68	G3/8	M16x1,5	20	14,5	M8	35	25	4	38,5	37	121	158	17	42	24	8

Type: **RXDCM**

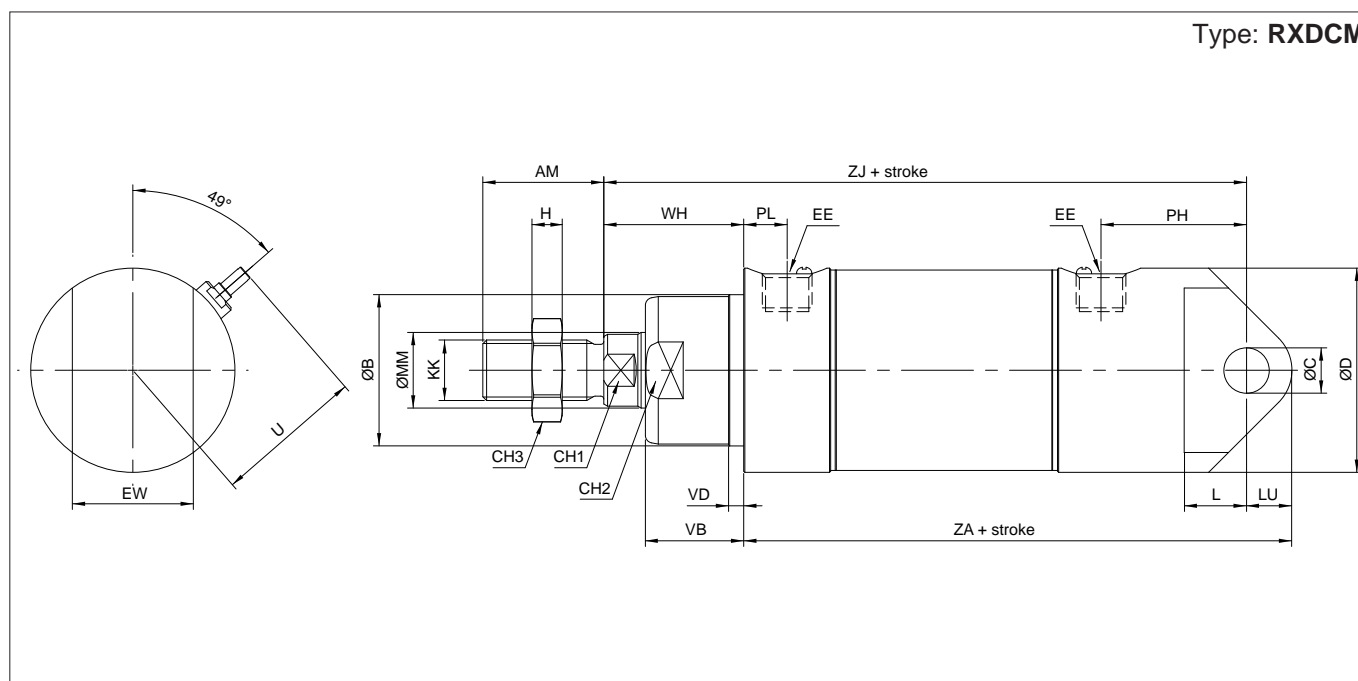

Ø (mm)	AM	ØB d11	ØC H8	ØD	EE	EW	KK	ØMM f7	L	LU	PH	PL	VB	VD	U	WH	ZA +1 0 stroke	ZJ +1 0 stroke	CH1	CH2	CH3	H
32	22	30	10	36	G1/8	26	M10x1,25	12	13	9	32,5	10,5	20	4	26,5	26	125	142	10	29	17	5
40	24	35	12	45	G1/4	28	M12x1,25	16	16	10	37	12	22	4	31	30	140	160	13	33	19	6
50	32	40	12	54	G1/4	32	M16x1,5	20	16,5	12	37	11,5	26	4	39,5	37	145	170	17	38	24	8
63	32	45	16	68	G3/8	40	M16x1,5	20	21	12	46	14,5	25	4	38,5	37	165	190	17	42	24	8

Stainless Steel Round Cylinders

Bores from 32 to 63 mm *Standard dimensions*



Type: **RXDCS**

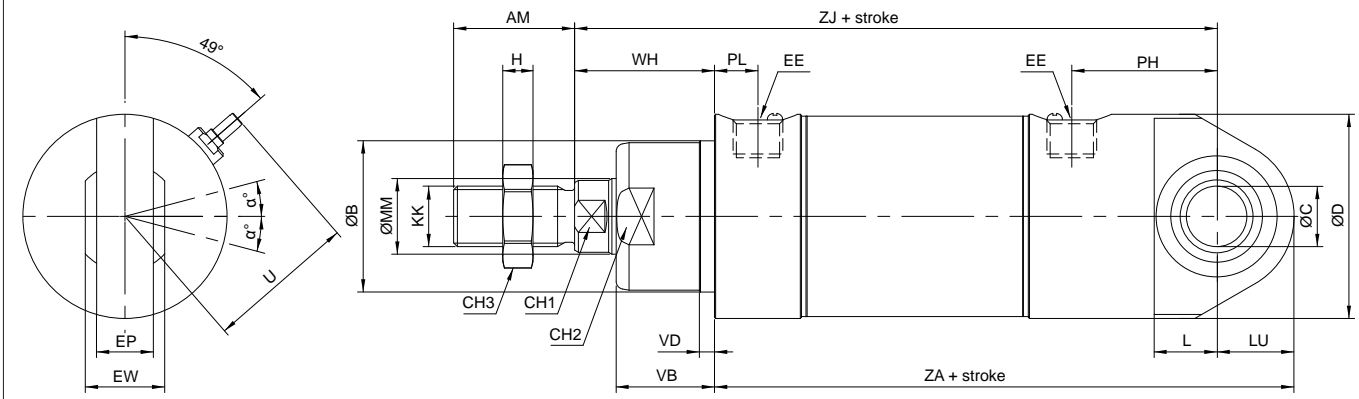

Ø (mm)	AM	ØB d11	ØC H7	ØD	EE	EP	EW	KK	ØMM f7	L	LU	PH	PL	VB	VD	U	WH	ZA +1 0	ZJ +1 0	CH1	CH2	CH3	H	α°
32	22	30	10	36	G1/8	10,5	14	M10x1,25	12	13	15	32,5	10,5	20	4	26,5	26	131	142	10	29	17	5	13
40	24	35	12	45	G1/4	12	16	M12x1,25	16	16	19	37	12	22	4	31	30	149	160	13	33	19	6	13
50	32	40	12	54	G1/4	15	21	M16x1,5	20	16,5	20,5	38,5	11,5	26	4	39,5	37	153,5	170	17	38	24	8	15
63	32	45	16	68	G3/8	15	21	M16x1,5	20	21	24	46,5	14,5	25	4	38,5	37	177	190	17	42	24	8	15

Type: **RXDCF**

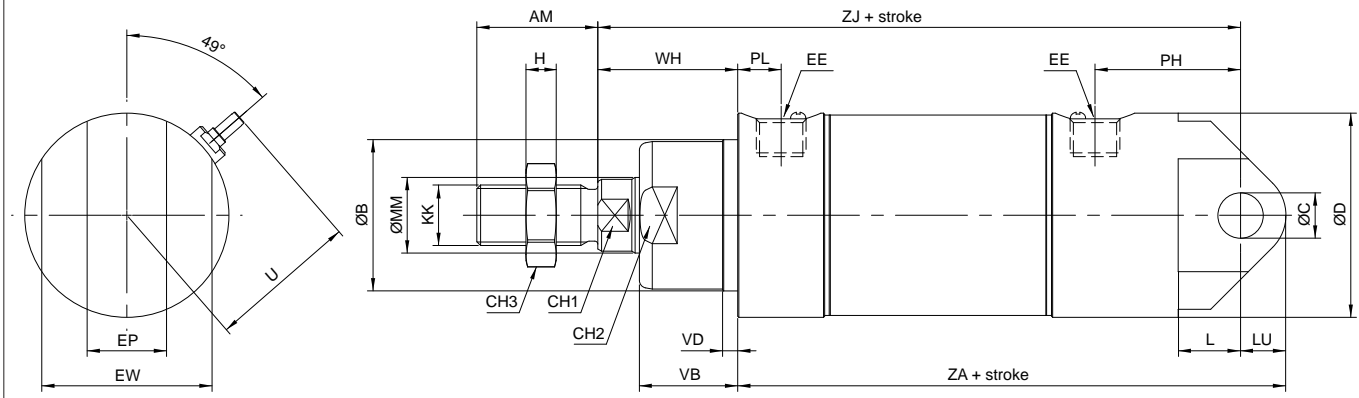

Ø (mm)	AM	ØB d11	ØC H8	ØD	EE	EP	EW	KK	ØMM f7	L	LU	PH	PL	VB	VD	U	WH	ZA +1 0	ZJ +1 0	CH1	CH2	CH3	H
32	22	30	10	36	G1/8	14	34	M10x1,25	12	13	9	32,5	10,5	20	4	26,5	26	125	142	10	29	17	5
40	24	35	12	45	G1/4	16	40	M12x1,25	16	16	10	37	12	22	4	31	30	140	160	13	33	19	6
50	32	40	12	54	G1/4	21	45	M16x1,5	20	16,5	12	37	11,5	26	4	39,5	37	145	170	17	38	24	8
63	32	45	16	68	G3/8	21	51	M16x1,5	20	21	12	46	14,5	25	4	38,5	37	165	190	17	42	24	8

Stainless Steel Round Cylinders

Bores from 32 to 63 mm *Standard dimensions*



Type: **RXDBA**

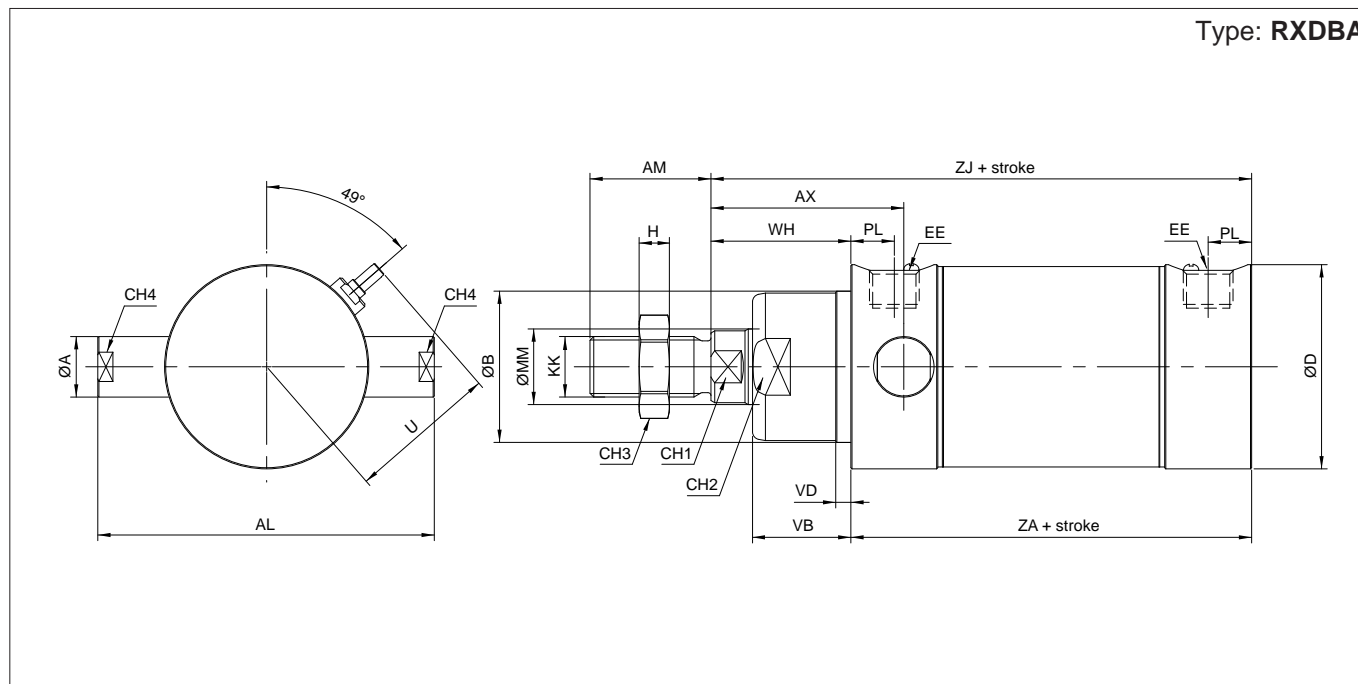

Ø (mm)	ØA f7	AL	AX	AM	ØB d11	ØD	EE	KK	ØMM f7	PL	VB	VD	U	WH	ZA +1 0	ZJ +1 0	CH1	CH2	CH3	CH4	H
32	12	67	39	22	30	36	G1/8	M10x1,25	12	10,5	20	4	26,5	26	94	120	10	29	17	10	5
40	12	76	43	24	35	45	G1/4	M12x1,25	16	12	22	4	31	30	105	135	13	33	19	10	6
50	16	89	40	32	51	54	G1/4	M16x1,5	20	11,5	26	4	39,5	37	106	143	17	38	24	14	8
63	16	103	47	32	47	68	G3/8	M16x1,5	20	14,5	25	4	38,5	37	121	158	17	42	24	14	8

Type: **RXDBP**

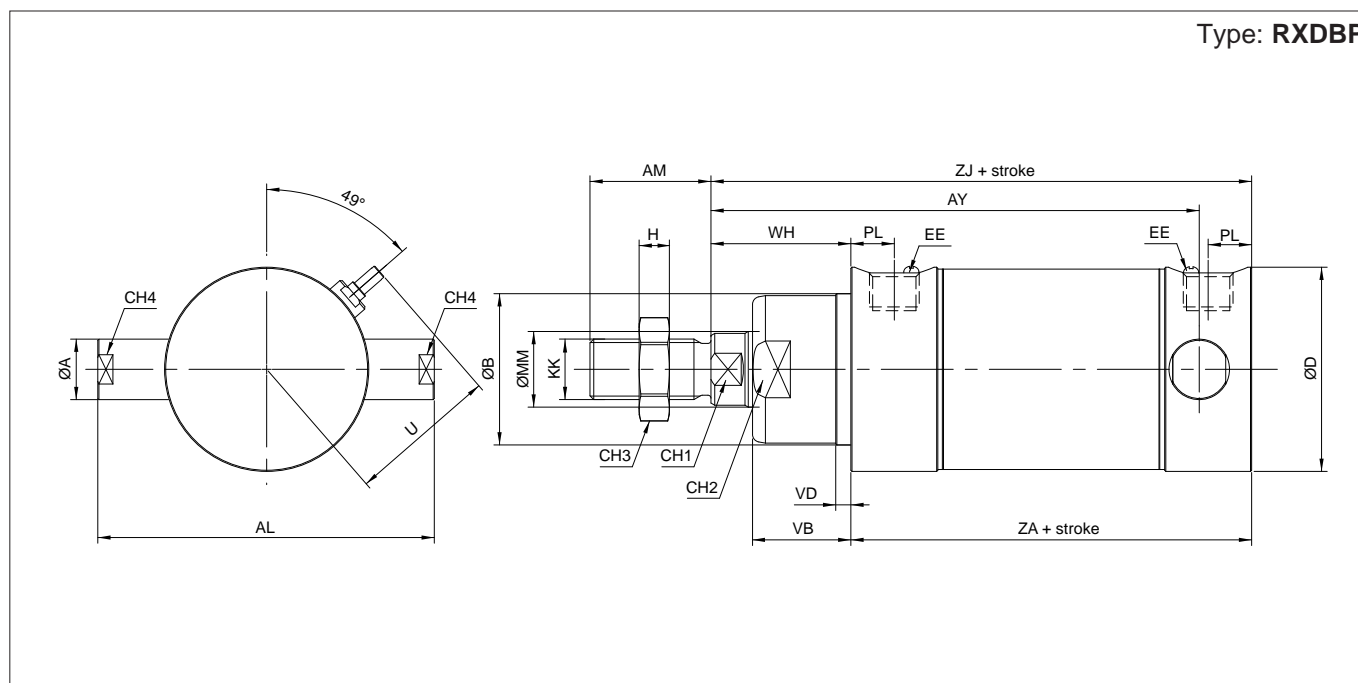

Ø (mm)	ØA f7	AL	AY	AM	ØB d11	ØD	EE	KK	ØMM f7	PL	VB	VD	U	WH	ZA +1 0	ZJ +1 0	CH1	CH2	CH3	CH4	H
32	12	67	110	22	30	36	G1/8	M10x1,25	12	10,5	20	4	26,5	26	94	120	10	29	17	10	5
40	12	76	122	24	35	45	G1/4	M12x1,25	16	12	22	4	31	30	105	135	13	33	19	10	6
50	16	89	129	32	40	54	G1/4	M16x1,5	20	11,5	26	4	39,5	37	106	143	17	38	24	14	8
63	16	103	148	32	45	68	G3/8	M16x1,5	20	14,5	25	4	38,5	37	121	158	17	42	24	14	8

Stainless Steel Round Cylinders

Bores from 32 to 63 mm

Options / Mounting accessories

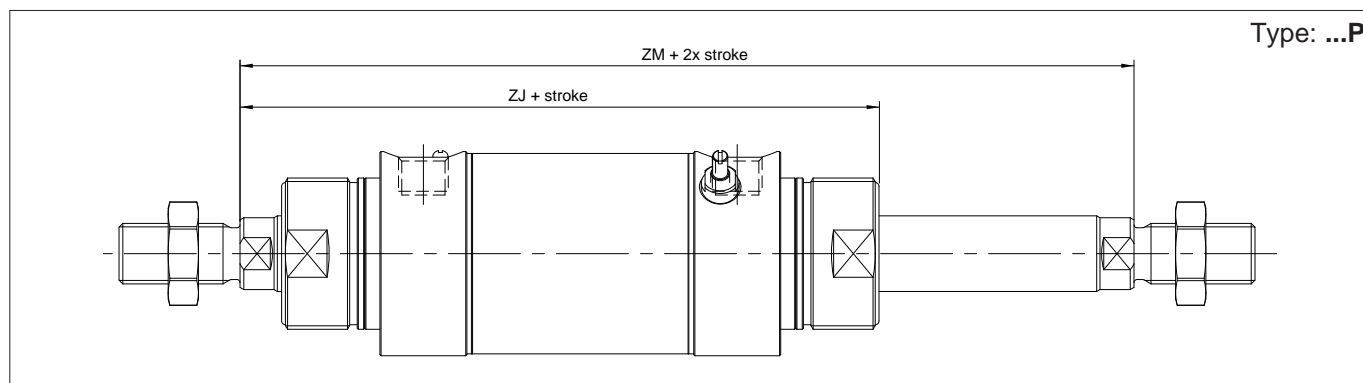

Type: ...P

Ø (mm)	ZM	ZJ
32	146	140
40	165	157
50	180	169
63	195	183

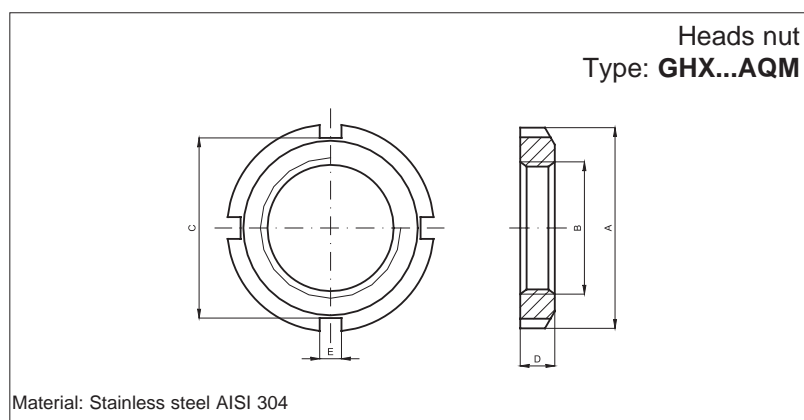

Material: Stainless steel AISI 304

Code	Item	Ø mm	A	B	C	D	E
040066	GHX32AQM	32	Ø 45	M30x1,5	40	7	5
040187	GHX40AQM	40	Ø 50	M38x1,5	46	8	5
040188	GHX50/63AQM	50/63	Ø 58	M45x1,5	52	9	6