

Version	Symbol	Type
Slow starter		V61

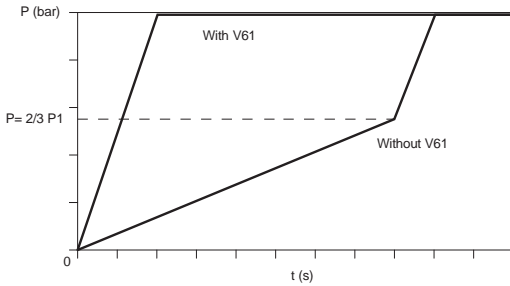

This fitting allows for a progressive pressurization of the installation and prevents the actuators from being hit hard in case of sudden pressure feeding of the previously vented circuit.

Depending on the desired spindle setting, the Slow Start Fitting will open gradually, pressure will progressively flow into the circuit and the actuators will go back to their working position without being hit. Pressure feeding speed is indeed determined by the rotation of the spindle.

If turned clockwise, a very smooth pressurization will be achieved.

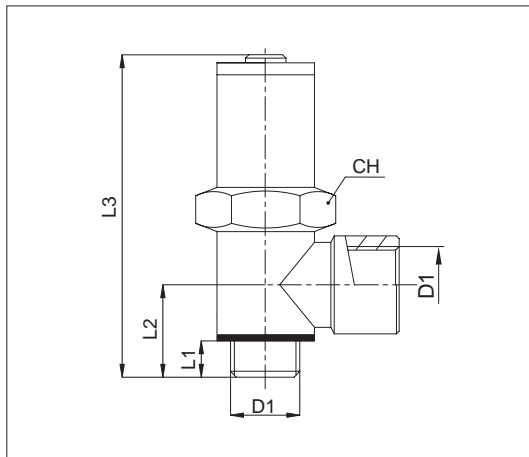

Code	Item	D ₁	D ₂	L ₁	L ₂	L ₃	CH
024475	V61 00 14	1/4"	1/4"	6,5	17	66	20
024476	V61 00 38	3/8"	3/8"	9	21	71,5	20
024477	V61 00 12	1/2"	1/2"	10	24,5	74,5	25

Technical data

Fluid	Compressed air
Pressure range	3 ÷ 10 bar (P1) - Total opening 2/3 P1
Temperature range	0 °C ÷ + 70°C
Parallel threads	UNI - ISO 228 / 1 (BSP)
Flow rate at 6 bar (NI/min)	1/4" = 1800 - 3/8" = 2400 - 1/2" = 2900
Materials	Body: Nickel plated brass Spring: Stainless steel AISI 302 Seals: Nitrile rubber (NBR) - Polyurethane (PU) Rondello: Nylon (PA6)