

Standard executions		
Version	Sym.	Type
Rear eye		CM..AQUN
Rear clevis		CF..AQUN
Flange		FL..AQUN
Low foot		PB..AQUN

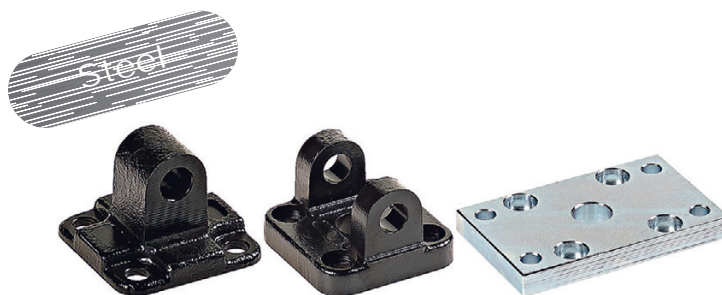

Technical data				
Type	Materials and treatments			
	Steel A105	Fe 37	Black cathaphoresis	White zinking
CM..AQUN	•		•	
CF..AQUN	•		•	
FL..AQUN		•		•
PB..AQUN		•		•

Note: The mounting screws are to be ordered separately.
For screws see page 1.101.1.

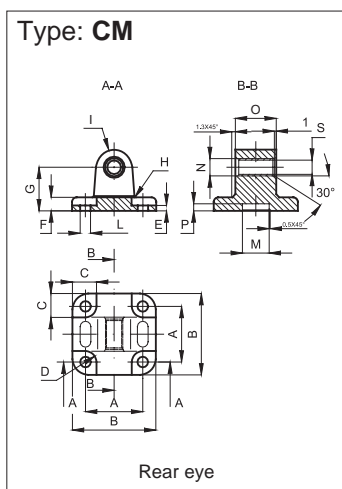

Code	Item	For cyl. Ø mm	A	B	C	D	E	F	G	H	I	L	M	N	O	P	Q	R	S	Weight (g)
040732	CM20AQUN	20	22	34	11	5	2,6	6	20	2	8	5,5	12	10	16	3	6	28	8	64
040733	CM25AQUN	25	26	38	11	5	2,6	6	20	2	8	5,5	12	10	16	3	6	28	8	80

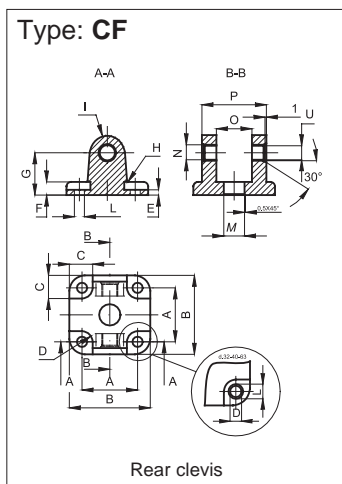

Code	Item	For cyl. Ø mm	A	B	C	D	E	F	G	H	I	L	M	N	O	P	Q	R	S	T	U	Weight (g)
040741	CF32AQUN	32	32	48	-	11	5,5	9	22	2,5	10	6,6	14	12	26	45	1,3	1,5	32	8	10	178
040742	CF40AQUN	40	42	58	-	11	5,5	9	25	2,5	12,5	6,6	14	14	28	52	1,3	1,3	37,5	9	12	313
040743	CF50AQUN	50	50	66	15,5	7,5	6,5	11	27	2,5	12,5	9	18	14	32	60	1,5	1,5	39,5	8	12	431
040744	CF63AQUN	63	62	83	-	15	6,5	11	32	4	15	9	18	18	40	70	1,5	1,5	47	10,5	16	707
040745	CF80AQUN	80	82	102	19	9	10	13	36	4	15	11	23	18	50	90	1,5	1,5	51	10	16	1213
040746	CF100AQUN	100	103	123	19	9	10	15	41	4	20	11	28	23	60	110	1,5	1,5	61	9	20	2200

The pin is to be ordered separately: for the pin see page 1.98.2 (SEC..AQIS).

Mounting Accessories for Cylinders

Mountings for compact UNITOP in steel



Type: FL

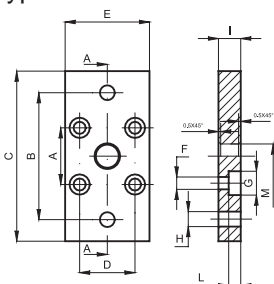

Flange $\varnothing 12 \div 25$ mm.

Code	Item	For cyl. \varnothing mm	A	B	C	D	E	F	G	H	I	L	M	Weight (g)
040751	FL12-16AQUN	12-16	18	43	55	18	29	4,5	9	5,5	10	5,4	10	10
040752	FL20AQUN	20	22	55	70	22	36	5,5	10	6,6	10	5,4	12	16
040753	FL25AQUN	25	26	60	76	26	40	5,5	10	6,6	10	5,4	12	20

Type: FL

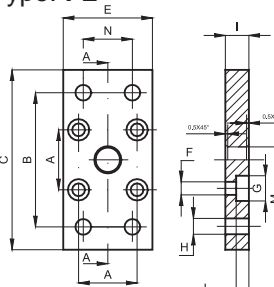

Flange $\varnothing 32 \div 100$ mm.

Code	Item	For cyl. \varnothing mm	A	B	C	D	E	F	G	H	I	L	M	N	Weight (g)
040754	FL32AQUN	32	32	65	80	32	50	6,6	11	7	10	6,4	14	32	260
040755	FL40AQUN	40	42	82	102	42	60	6,6	11	9	10	6,4	14	36	420
040756	FL50AQUN	50	50	90	110	50	68	9	15	9	12	8,6	18	45	600
040757	FL63AQUN	63	62	110	130	62	87	9	15	9	15	8,6	18	50	1200
040758	FL80AQUN	80	82	135	160	82	107	11	18	12	15	10,6	23	63	1800
040759	FL100AQUN	100	103	163	190	103	128	11	18	14	15	10,6	28	75	2550

Type: PB

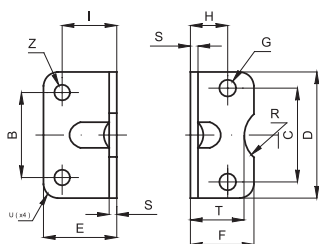

Low foot $\varnothing 12 \div 32$ mm.

It is supplied singly.

Code	Item	For cyl. \varnothing mm	C	B	D	E	F	G	H	I	S	T	R	U	Z	Weight (g)
040761	PB12-16AQUN	12-16	18	18	30	17,5	17,5	4,4	13	13	3	15	9	2	5,5	20
040762	PB20AQUN	20	22	22	36	22	22	5,4	16	16	4	17	10	2	6,6	32
040763	PB25AQUN	25	26	26	40	22	23	5,4	17	16	4	19	11	2	6,6	38
040764	PB32AQUN	32	32	32	50	26	24	6,6	16	18	5	20	12	2	6,6	66

Type: PB

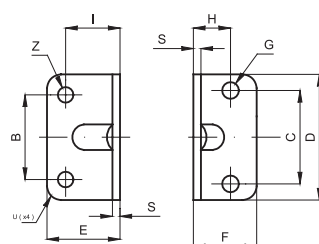

Low foot $\varnothing 40 \div 100$ mm.

It is supplied singly.

Code	Item	For cyl. \varnothing mm	C	B	D	E	F	G	H	I	S	U	Z	Weight (g)
040765	PB40AQUN	40	42	42	60	28	29,5	6,6	21,5	20	5	5	9	100
040766	PB50AQUN	50	50	50	68	32	30	9	22	24	6	5	9	150
040767	PB63AQUN	63	62	62	84	39	39	9	28,5	27	6	5	11	250
040768	PB80AQUN	80	82	82	102	42	36,5	11	24,5	30	8	5	11	380
040769	PB100AQUN	100	103	103	123	45	38,5	11	26,5	33	8	5	13,5	500