

Standard executions		
Version	Symbol	Type
Guided		S3
Short guided (for light loads)		S5
Double guide		S6



Rodless cylinders, magnetic as standard. Cylinders with direct power transmission through the tube slot onto the yoke. The new cushionings are adjustable at both ends; the flow rate is regulated from 0 to 100% by turning a pin of an angle of 90°. The new barrel is provided with grooves for fixing various accessories. The magnetic switches can be fixed by a bracket or directly in the tube; the reed switch will not protrude out the barrel profile. The side carriage (which can also be installed at a later date) is adjustable and this allows to use the cylinder with heavier loads; the guide moves by Teflon slides, fixed in the grooves of the tube. The short guided cylinders type S5, in comparison to the standard cylinder - 0 - stroke, is up to 42% shorter; the total fitting length is therefore reduced and the cylinder is more compact and money-saving.

Options	Suffix
Both connections on one head from bore 25 mm.	U
Special versions on request	/ S

The options can be combined (when this is possible).

For parameters of the loads and moments see from page 1.26.25.
For seal kits see from page 1.26.21.

For the magnetic reed switches ASV-ASC see page 1.26.40.
For mounting accessories see from page 1.26.28.

How to order: 50 / 1000 S6U

50	/	1000	S6	U
Bore	/	Stroke	Type	Option

Technical data	
Fluid	Compressed filtered air with or without lubrication. Lubrication, if started, must be continued.
Pressure	2 ÷ 8 bar
Temperature range	-20 °C ÷ + 80°C
Materials	Heads: Anodised aluminium Tube: Anodised aluminium Seals: Polyurethane - Piston: monobloc/yoke: Aluminium Internal strip: Nylon External strip: Stainless steel AISI 304 Wiper ring: PVC Carriage: Aluminium

Bore (mm)	Standard strokes (mm)	Max stroke (mm)	Cushion length (mm)	Theoretical force at 6 bar (N)	Weight at 0 stroke Type S3 (g)	Weight at 0 stroke Type S5 (g)	Weight at 0 stroke Type S6 (g)	Weight for every 10 mm stroke (g)
18	from 10 to 6000	9000	15	140	400	250	500	15
25			18	270	900	550	1200	26
32			24	440	1500	1100	1900	36
40			34	680	2800	1700	3800	48
50			40	1060	4900	2850	6600	74
63			49	1680	8000	4400	10400	101

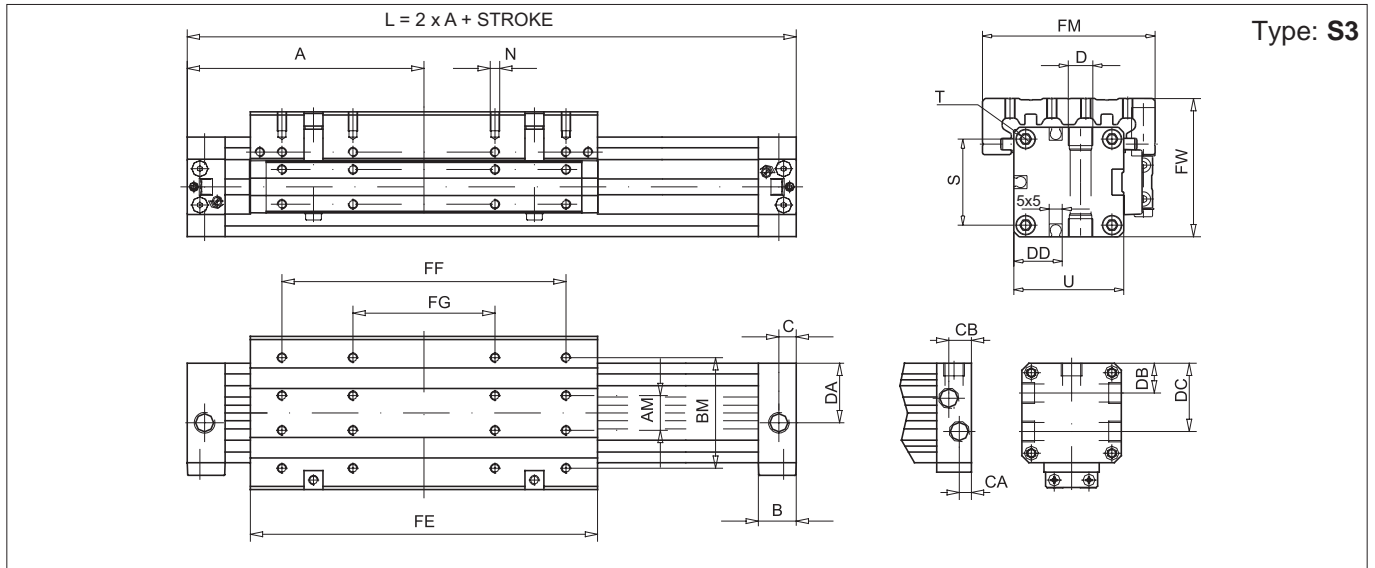

Ø mm	A	AM	B	BM	C	CA	CB	D	DA	DB	DC	DD	FE	FF	FG	FM	FW	N	□ S	T	□ U
18	80	10	16,5	35	6,5	-	-	M7x1/6	17,5	-	-	-	103	75	-	50	39	M4x7,5	23,5	M3x7	30
25	100	13	20	45	8,5	7	13	G1/8x8	25,5	14	28	18,5	131	100	50	66	53	M4x8	33	M4x9	42
32	120	16	20	55	8,5	7	13	G1/8x8	32	17,5	34,5	21	171	140	70	80	65	M5x10	41	M5x10	52
40	150	22	24	70	13	9,5	14,5	G1/4x12	37,5	20	42	29,5	220	180	90	97	79	M6x12	51	M6x12	63
50	180	29	24	85	13	9,5	14,5	G1/4x12	47,5	26	52	37	280	220	110	116	96	M8x16	63	M8x12	78
63	215	40	30	105	13	11	18,5	G3/8x12	59,5	30	62	44,5	333	280	140	136	113,5	M8x16	78	M8x12	93

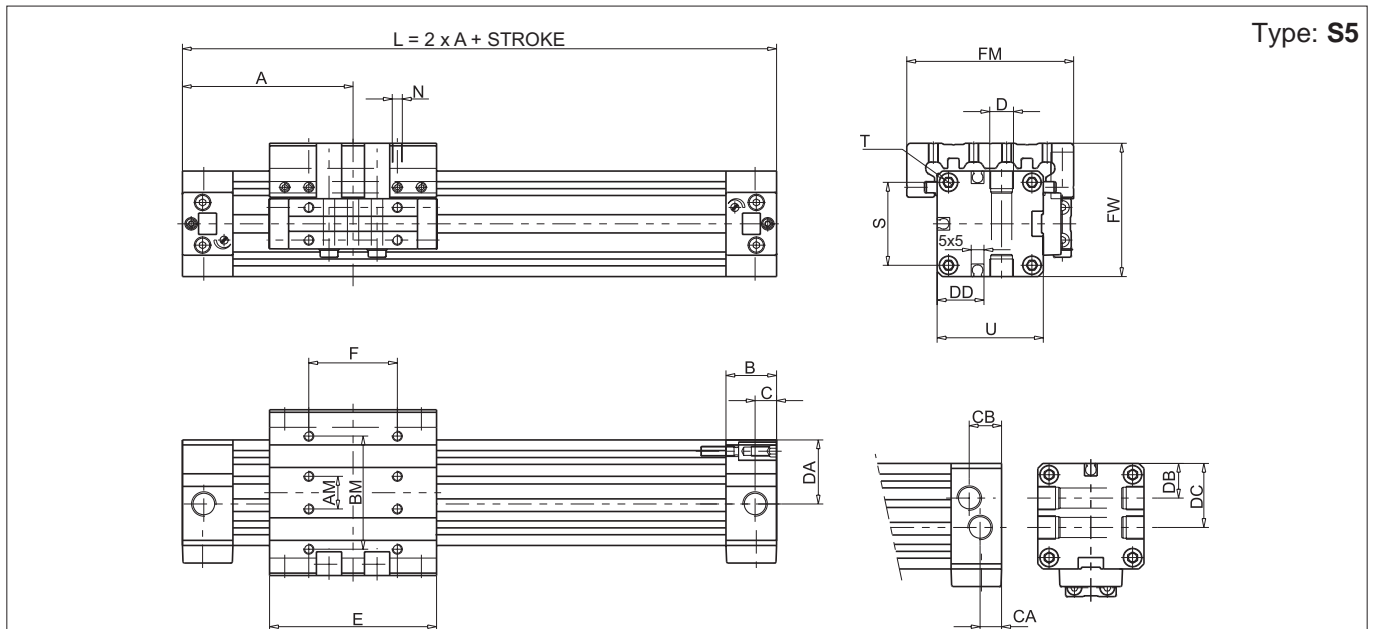

Ø mm	A	AM	B	BM	C	CA	CB	D	DA	DB	DC	DD	E	F	FM	FW	N	□ S	T	□ U
18	57,5	10	16,5	35	6,5	-	-	M7x1/6	17,5	-	-	15	58	30	50	39	M4x7,5	23,5	M3x7	30
25	67,5	13	20	45	8,5	7	13	G1/8x8	25,5	14	28	21	66	35	66	53	M4x8	33	M4x9	42
32	77,5	16	20	55	8,5	7	13	G1/8x8	32	17,5	34,5	26	86	55	80	65	M5x10	41	M5x10	52
40	95	22	24	70	13	9,5	14,5	G1/4x12	37,5	20	42	31,5	110	70	97	79	M6x12	51	M6x12	63
50	105	29	24	85	13	9,5	14,5	G1/4x12	47,5	26	52	39	130	70	116	96	M8x16	63	M8x12	78
63	125	40	30	105	13	11	18,5	G3/8x12,5	59,5	30	62	46,5	153	100	136	113,5	M8x16	78	M8x12	93

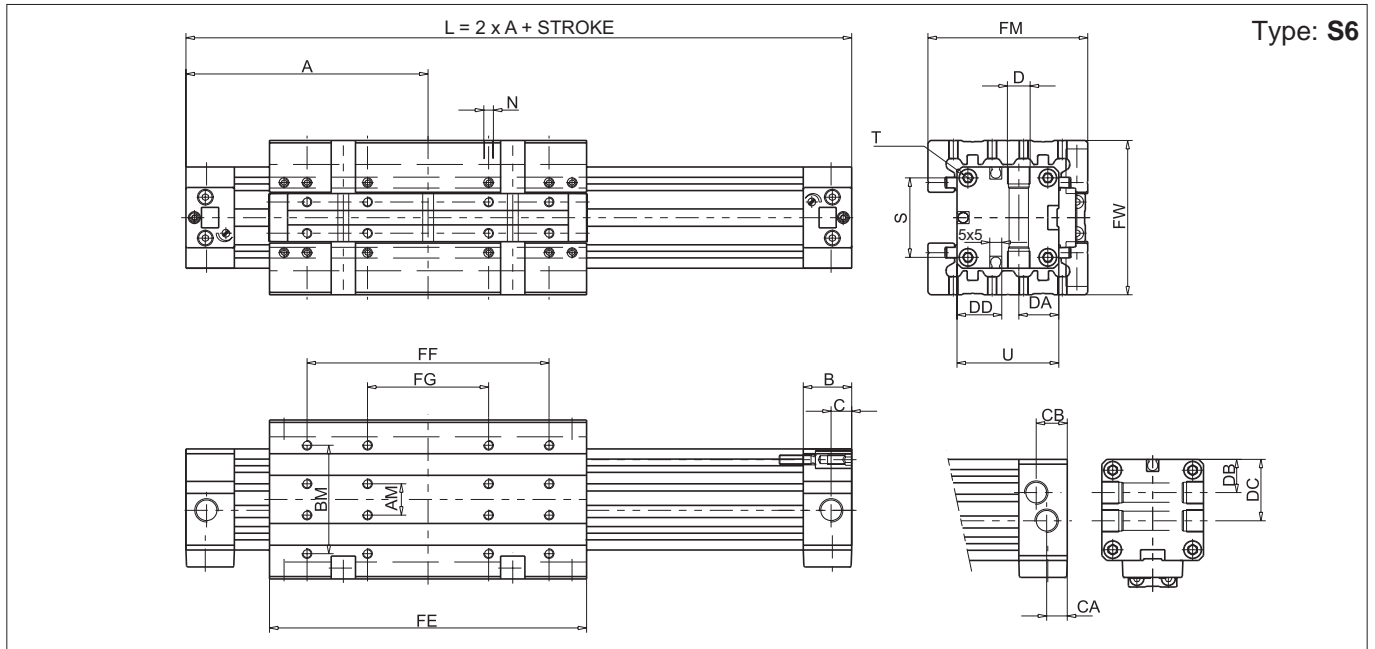

Ø mm	A	AM	B	BM	C	CA	CB	D	DA	DB	DC	DD	FE	FF	FG	FM	FW	N	□ S	T	□ U
18	80	10	16,5	35	6,5	-	-	M7x1/6	17,5	-	-	-	103	75	--	50	48	M4x7,5	23,5	M3x7	30
25	100	13	20	45	8,5	7	13	G1/8x8	25,5	14	28	18,5	131	100	50	66	64	M4x8	33	M4x9	42
32	120	16	20	55	8,5	7	13	G1/8x8	32	17,5	34,5	21	171	140	70	80	78	M5x10	41	M5x10	52
40	150	22	24	70	13	9,5	14,5	G1/4x12	37,5	20	42	29,5	220	180	90	97	95	M6x12	51	M6x12	63
50	180	29	24	85	13	9,5	14,5	G1/4x12	47,5	26	52	37	280	220	110	116	114	M8x16	63	M8x12	78
63	215	40	30	105	13	11	18,5	G3/8x12	59,5	30	62	44,5	333	280	140	136	134	M8x16	78	M8x12	93

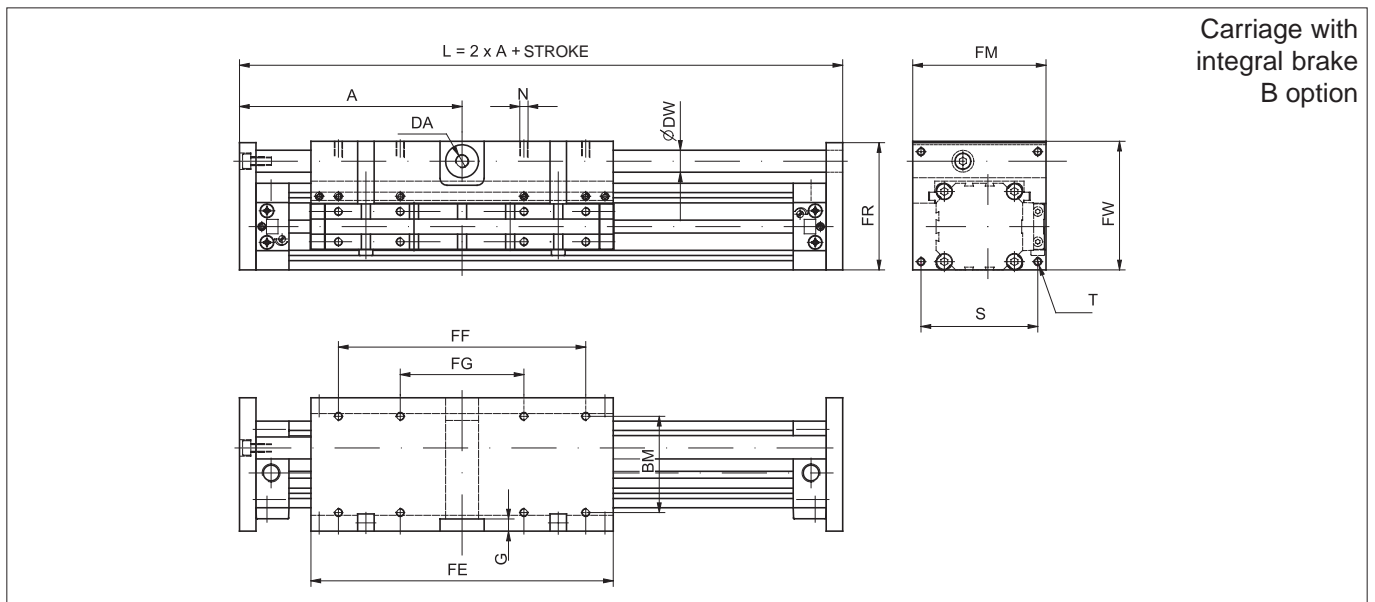

Should it be necessary to lock a working or a handling, the carriage with integral brake can be used.
Materials: carriage: Aluminium; rod: Hardened and chrome plated steel.

Ø mm	A	BM	D	DA	DW	FE	FF	FG	FM	FW	FR	G	N	S	T	U	Fb
18	86	35	M5-5,5	M5	Ø 6	103	75	-	50	48	47	6	M4-7,5	42	M3	6	180N
25	110	45	1/8"-7,7	M5	Ø 12	131	100	50	66	67	66	-	M4-8	54	M4	10	600N
32	130	55	1/8"-7,7	M5	Ø 12	171	140	70	80	79	78	5	M5-10	68	M5	10	600N
40	162	70	1/4"-11,7	1/8"	Ø 16	220	180	90	97	93,5	92,5	-	M5-12	80	M6	12	1000N
50	195	85	1/4"-11,7	1/8"	Ø 20	280	220	110	116	11,5	114,5	-	M8-16	100	M8	15	1400N
63	230	105	3/8"-11,7	1/8"	Ø 25	333	280	140	136	139	138	-	M8-16	120	M8	15	2500N